



Product Fact Sheet

—
Moonbeam
Lim + Lu

lucie kaas

COLLECTION
Moonbeam

Moonbeam, made from ribbed frosted glass and steel is a modern interpretation of the classic Asian paper lantern. The collection marks the first collaboration between Lucie Kaas and the award-winning design duo Lim+Lu.

VARIATIONS & DIMENSIONS



Large Pendant
MB01P (US)



Small Pendant
MB02P (US)



Table/Wall Lamp
MB02T (US)



Hook
MB-HOOK
16,5 cm / 6.5"
14,8 cm / 5.8"

length:
Height:
Diameter:
Chord:
Wire:

42 cm / 16.5"
40 cm / 15.7"
310 cm / 122"
300 cm / 118.1"

55,5 cm / 21.85"
16 cm / 15.35"
310 cm / 122"
300 cm / 118.1"

55,5 cm / 21.85"
16 cm / 15.35"
310 cm / 122"

SPECIFICATIONS

Moonbeam

Pendant Lamp

Designer

Lim + Lu

Country of origin

China

Year of Design

2019

Environment

Indoor

Material

Shade: Opal glass
Base: Powder coated steel
Wire: Steel
Chord: Fabric

Color specification

Shade: White
Base: Black
Chord: Black

Bulb included

No

Dimmable

No

Care & Cleaning

Clean with a soft dry cloth. Always switch off the electricity supply before cleaning

Assembly Instruction

Assembly manual is included with every lamp. Note that EU and US versions assembly instructions are different. The Hook does not include screws.

RATING & SPECIFICATIONS

	EU	UL
Socket:	E27	E26
Light Source:	MAX 25W	MAX 25W
Voltage:	220-240	110-120
Frequency:	50-60Hz	60Hz
IP Rating:	IP20	

Table Lamp

Pendant Lamp



Classification Class II

Classification Class I

ENERGY EFFICIENCY

The luminaire is compatible with bulbs of the energy classes: A++ - E

lucie kaas Art. Nr. MB01P

 This luminaire is compatible with bulbs of the energy classes:

A++
A+
A
B
C
D
E

874/2012 

lucie kaas Art. Nr. MB02P

 This luminaire is compatible with bulbs of the energy classes:

A++
A+
A
B
C
D
E

874/2012 

lucie kaas Art. Nr. MB02T

 This luminaire is compatible with bulbs of the energy classes:

A++
A+
A
B
C
D
E

874/2012 

Assembly Instruction

Moonbeam

Pendant Lamp

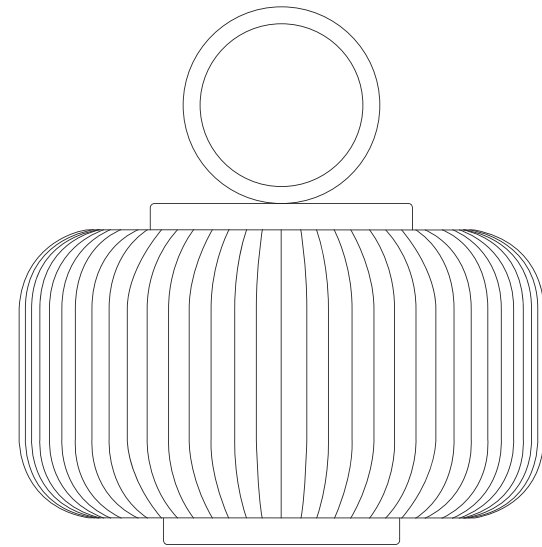

HARDWARE IDENTIFICATION



BEFORE ASSEMBLY

- 1 Read through the instructions carefully before starting assembly.
- 2 Check the contents of the package
(contact the point of sale if you find anything defective or missing).
- 3 Make sure that the indicated tools are available.
- 4 All lights must be wired according to Local and National electrical codes.
- 5 To be installed by a professional electrician.
- 6 Assemble step by step as shown in the instructions.
- 7 It is a good idea to use a soft, protective underlay during assembly.

CAUTION

All electrical components are CUL approved with this fixture

To reduce the risk of fire, use
max 40 watt E26
120V 60HZ AC Only

SOME USEFUL ADVISE

- All lights must be wired according to Local and National electrical codes.
- To be installed by a professional electrician.
- You should check and re-tighten the screws and bolts a few weeks after assembly.
- For cleaning, use mild soapy water only and dry with a soft cloth
(other cleaning agents may cause damage not covered by warranty.)

Please keep this assembly instruction in a safe place for future reference.



120V 60Hz
E26 TYPE A Max 40W

Bulb not included

Assembly Instruction

Moonbeam

Pendant Lamp

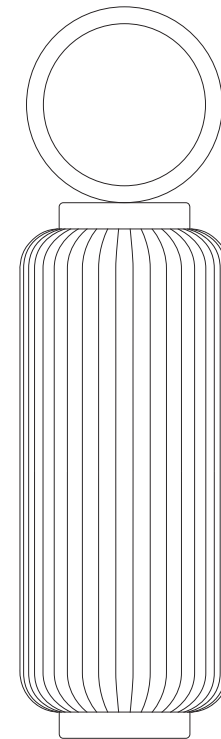

HARDWARE IDENTIFICATION



BEFORE ASSEMBLY

- 1 Read through the instructions carefully before starting assembly.
- 2 Check the contents of the package (contact the point of sale if you find anything defective or missing).
- 3 Make sure that the indicated tools are available.
- 4 All lights must be wired according to Local and National electrical codes.
- 5 To be installed by a professional electrician.
- 6 Assemble step by step as shown in the instructions.
- 7 It is a good idea to use a soft, protective underlay during assembly.

CAUTION

All electrical components are CUL approved with this fixture

To reduce the risk of fire, use
max 40 watt E26
120V 60HZ AC Only

SOME USEFUL ADVISE

- All lights must be wired according to Local and National electrical codes.
- To be installed by a professional electrician.
- You should check and re-tighten the screws and bolts a few weeks after assembly.
- For cleaning, use mild soapy water only and dry with a soft cloth (other cleaning agents may cause damage not covered by warranty.)

Please keep this assembly instruction in a safe place for future reference.

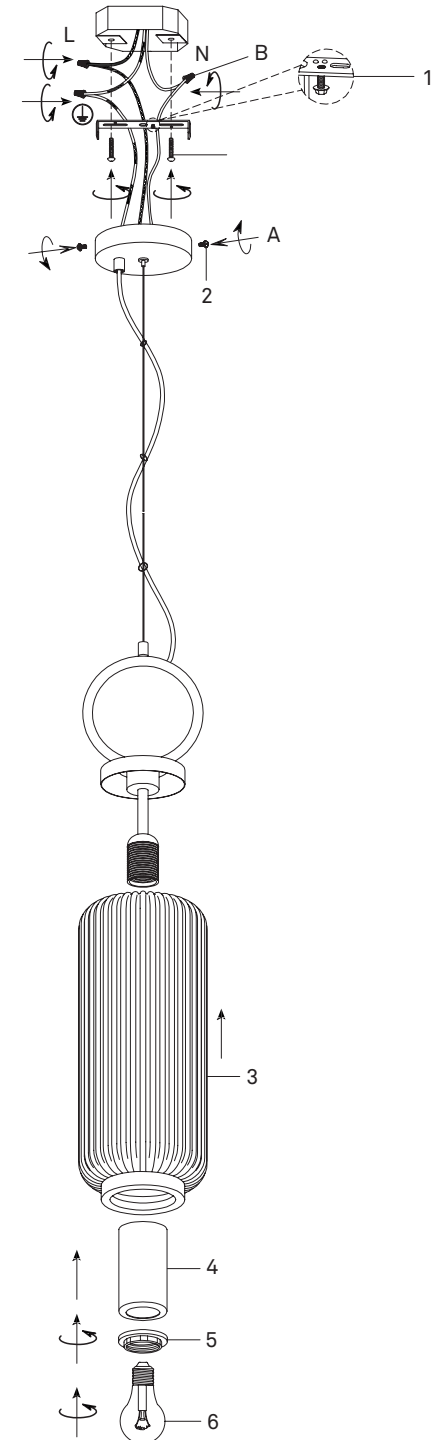

120V 60Hz
E26 TYPE A Max 40W
Bulb not included

Assembly Instruction

Moonbeam

Table Lamp

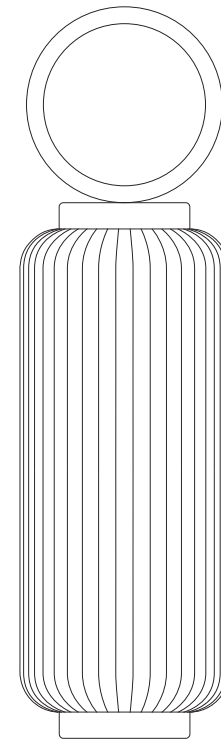

HARDWARE IDENTIFICATION



BEFORE ASSEMBLY

- 1 Read through the instructions carefully before starting assembly.
- 2 Check the contents of the package (contact the point of sale if you find anything defective or missing).
- 3 Make sure that the indicated tools are available.
- 4 All lights must be wired according to Local and National electrical codes.
- 5 To be installed by a professional electrician.
- 6 Assemble step by step as shown in the instructions.
- 7 It is a good idea to use a soft, protective underlay during assembly.

CAUTION

All electrical components are CUL approved with this fixture

To reduce the risk of fire, use
max 40 watt E26
120V 60HZ AC Only

SOME USEFUL ADVISE

- All lights must be wired according to Local and National electrical codes.
- To be installed by a professional electrician.
- You should check and re-tighten the screws and bolts a few weeks after assembly.
- For cleaning, use mild soapy water only and dry with a soft cloth (other cleaning agents may cause damage not covered by warranty.)

Please keep this assembly instruction in a safe place for future reference.

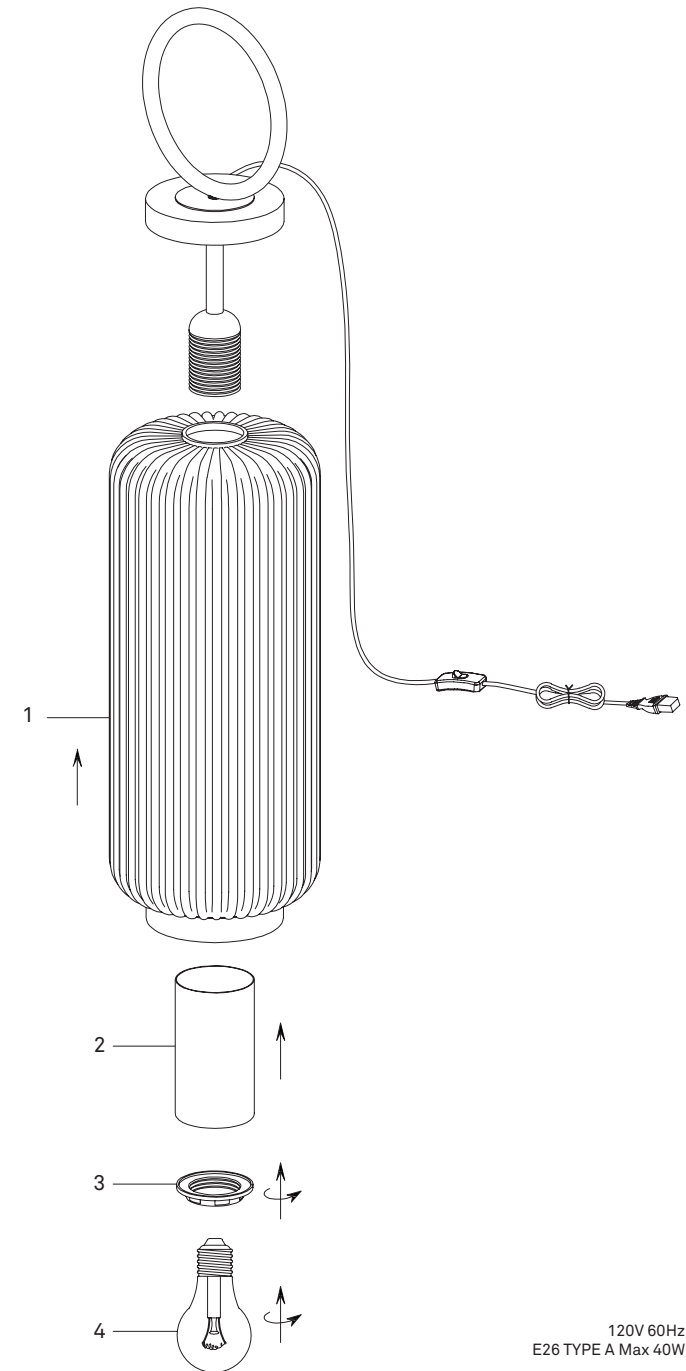

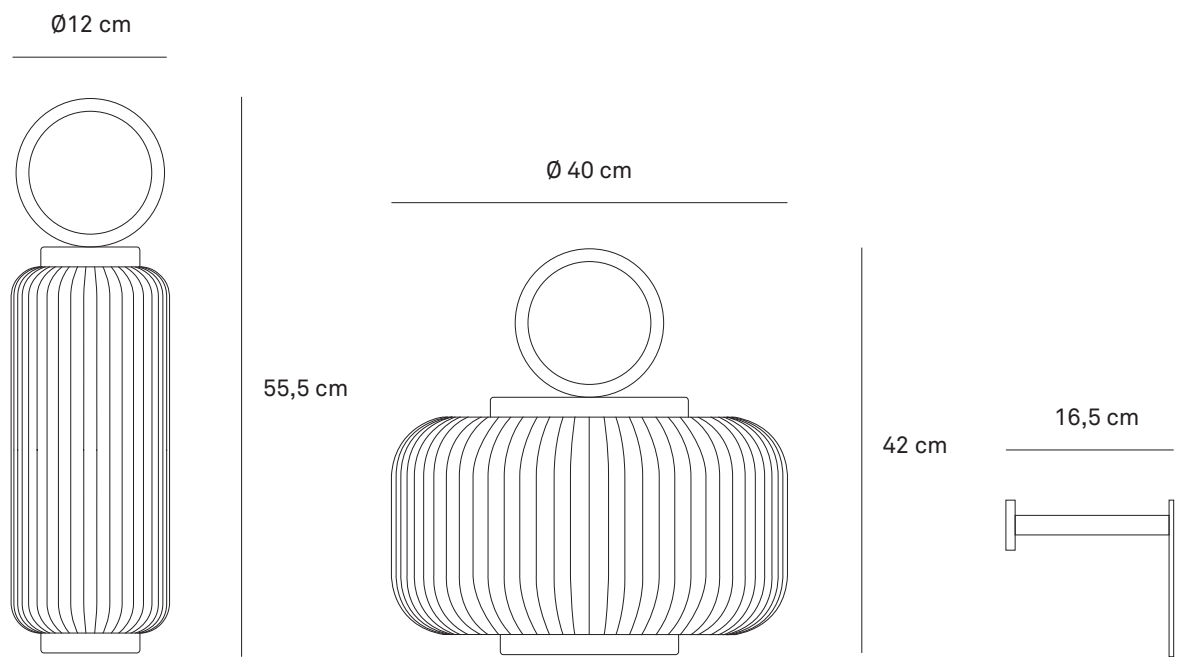

DIMENSION

—
Moonbeam
Lim + Lu

lucie kaas

